

# PERFLUOROOCCTANOIC ACID INTERACTIONS WITH HUMAN SERUM ALBUMIN

By GORDON L. NORDBY\* AND J. MURRAY LUCK

(From the Department of Chemistry, Stanford University, Stanford, California)

(Received for publication, August 1, 1955)

For several years perfluorooctanoic acid (1) ( $\text{CF}_3 \cdot (\text{CF}_2)_6 \cdot \text{COOH}$ ) has been used in this laboratory as a protein precipitant (2). Qualitatively it has been observed to bind so completely to proteins that little of the precipitant remains in the filtrate; this is an obvious advantage in chromatography and in various analytical procedures.

The purpose of the present study is to define the conditions under which perfluorooctanoic acid will effect a precipitation of human serum albumin and to describe in detail the interaction between these two reactants. Human serum albumin was used because of its unusual properties in binding a variety of ions.

## Materials

A solution of human serum albumin (decanol procedure) was electro-dialyzed at 40 volts per cm. against conductivity water and clarified by pressure filtration through a sterilizing filter pad. The product was lyophilized and stored at 3°; appropriate amounts of the powder were removed as needed for the preparation of albumin solutions.

Sodium perfluorooctanoate (PF8) solutions were prepared by carefully neutralizing a 0.5 per cent aqueous solution of the acid with a minimal volume of sodium hydroxide.

## Procedure

*Precipitation*—A number of buffered 0.3 per cent solutions of serum albumin in PF8 were prepared. Each solution was distinctive with respect either to its PF8 concentration or to its pH, the latter being determined by 0.1 M McIlvaine buffers (3). The pH of each solution was between 4.25 and 5.25. The PF8 concentration of each solution was such that the mole ratio (PF8 to albumin) ranged between 0 and 200.<sup>1</sup> The solutions were thoroughly mixed, allowed to stand for 15 minutes, and centrifuged in a clinical centrifuge at room temperature for 20 minutes. For conditions under which the protein in a given solution was only partially precipitated, opaque supernatant solutions were sometimes formed; in all other cases the

\* Public Health Service Research Fellow of the National Heart Institute.

<sup>1</sup> A value of 61,500 was used for the molecular weight of human serum albumin (4).

supernatant solutions were clear. An aliquot of each supernatant liquid, or solution if no precipitate existed, was then analyzed for protein by the Lowry *et al.* modification of the Folin test (5). PF8 does not interfere with this analysis. The percentage of albumin that was precipitated from each solution under the stated conditions of pH and PF8 concentration was calculated. The results appear in Fig. 1.

*Anion Binding*—A number of 0.3 per cent albumin solutions were prepared in radioactive PF8. The ratio (PF8 to albumin) in each solution was between 80 and 200. The solutions were then titrated at 25° to about pH 3 with hydrochloric acid. In the course of the titration between pH

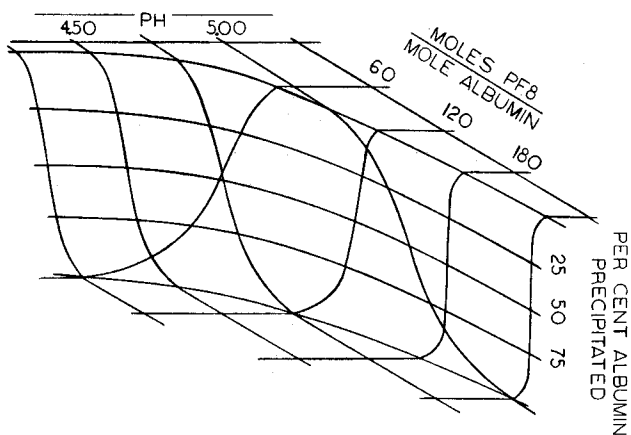

FIG. 1. The percentage of human serum albumin precipitated from aqueous solution is a function of the pH of the solution and the molar ratio (PF8 to albumin) in the system. For example, at pH 4.75 and a molar ratio (PF8 to albumin) of 60, about 48 per cent of the albumin is precipitated.

4 and 3, the protein precipitated completely; several 0.005 ml. aliquots were removed from each supernatant liquid, placed on aluminum disks, and immediately dried under an infra-red lamp. The disks were then placed on an automatic sample changer which operated into a gas flow counter (6). The time required for an arbitrary number of counts was recorded for the sample on each disk. After making suitable corrections for efficiency and background interference in the counting, the relative activities of the samples were determined and compared with the original activities of their respective solutions before the titration was started. The molar ratio (bound PF8 to albumin) in each solution was then calculated as a function of the molar ratio (PF8 to albumin). The data are given in Fig. 2.

*Hydrogen Ion Binding*—A number of 0.3 per cent albumin solutions were

prepared. Half of the solutions contained that concentration of PF8 for which the molar ratio (PF8 to albumin) was 196; the remaining solutions contained an equivalent concentration of sodium chloride. Each solution

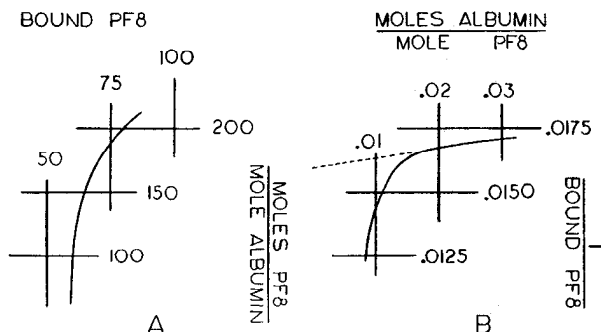

FIG. 2. Curve A, the molar ratio (PF8 to albumin) in a system determines the number of PF8 anions that bind to each albumin molecule. Curve B, the reciprocal of the number of PF8 anions bound to each albumin molecule is plotted against the molar ratio (albumin to free PF8).

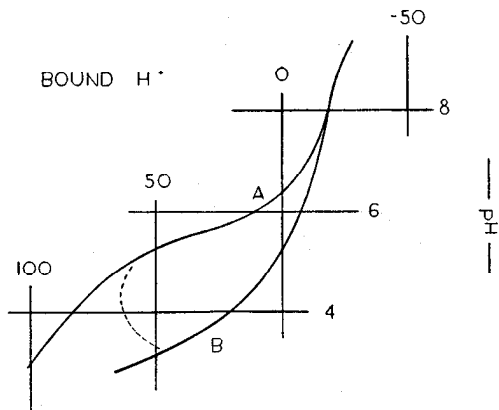

FIG. 3. The number of hydrogen ions bound to an albumin molecule is a function of the pH of the solution. Curve A represents 1 mole of albumin in the presence of sodium PF8; Curve B represents 1 mole of albumin in the presence of sodium chloride.

was then titrated at 25° with either hydrochloric acid or sodium hydroxide. The amount of hydrogen ion bound by the albumin, or dissociated from it, was calculated quite directly from the total acid or base added to a given solution and the amount of acid or base actually present in the solution as reflected by its pH. Subsequently, the charge on the albumin molecule was calculated as a function of pH. The data are presented in Fig. 3.

## DISCUSSION

*Precipitation*—Although Fig. 1 indicates a certain critical range of pH and PF8 concentration which must prevail for the precipitation of human serum albumin, it also indicates in a qualitative manner the conditions under which most other proteins would be expected to precipitate. Three rather striking features are noted for attention. (1) The conditions of pH and ionic strength under which complete albumin precipitation occurs are very mild. (2) The precipitation of albumin is completely reversible with respect to pH. An albumin precipitate formed in a PF8 solution can be completely dissolved by making the solution somewhat alkaline (pH 6 to 7) to the pH at which precipitation occurred. The minimal pH to which the solution must be raised will depend, of course, upon the PF8 concentration of the solution. (3) In acidic solutions, the precipitation of albumin is irreversible with respect to the PF8 concentration. Provided that an albumin precipitate is dialyzed against an appropriately acidic solution, it will not dissolve appreciably as the concentration of PF8 in equilibrium with the precipitate decreases. However, the PF8 precipitant can readily be dialyzed from albumin in neutral or slightly alkaline solutions.

*Anion Binding*—The scope of Curve A in Fig. 2 is restricted at the upper limit by the rather low solubility of PF8 in aqueous solution and at the lower limit by the concentration of PF8 which would adequately precipitate albumin under the conditions of the experiments. However, it is clear from the graph that a considerable number of PF8 anions bind to each albumin molecule. The molar ratio (bound PF8 to albumin) increases quite rapidly as the PF8 concentration is increased. In contrast, the molar ratio (bound PF8 to albumin) decreases very slowly as the molar ratio (PF8 to albumin) is decreased below about 120. In solutions containing the minimal concentration of PF8 which is effective in completely precipitating a given concentration of albumin, the PF8 is almost completely removed from the solution as part of the precipitating complex.

The data of Curve A are treated by an expression derived by Klotz (7); the results appear as Curve B of Fig. 2.

$$\frac{1}{r} = \frac{1}{Kn} \times \frac{1}{c} + \frac{1}{n}$$

In the above equation,  $r$  is the molar ratio (bound PF8 to albumin),  $n$  is the molar ratio (maximal bound PF8 to albumin),  $c$  is the molar ratio (free PF8 to albumin) in the solution, and  $K$  is a constant proportional to the equilibrium constant for the PF8 anion-binding reaction. The parameters in the above equation are  $1/r$  and  $1/c$ . Although there is no *a priori* evidence that the equation does apply to PF8 anion binding, it can be as-

sumed, by virtue of the linearity of a portion of Curve B, that the equation does apply to the linear portion. The indicated extrapolation to infinite PF8 concentration reveals that a maximum of 63 PF8 anions bind to an albumin molecule by reactions having nearly the same equilibrium constant. Additional anions are bound to albumin at high PF8 concentrations by some less easily described series of reactions. At very high PF8 concentrations, Curve B of Fig. 2 becomes nearly vertical; therefore the maximal number of PF8 anions that can possibly bind to an albumin molecule cannot be calculated by the evidence available. In contrast, a study of octanoic acid anion binding by Teresi and Luck (8) reveals that a total of 36 octanoate ions binds to two types of sites on the albumin molecule. Preliminary isotope dilution studies indicate that the PF8 anions are reversibly bound to the albumin molecule.

*Hydrogen Ion Binding*—Two hydrogen ion binding curves for human serum albumin are depicted in Fig. 3. These binding curves are completely applicable to reversible titrations over the pH range illustrated. It is readily apparent from these curves that PF8 strongly influences the albumin molecule charge in acid solution. A similar effect has been observed by Steinhardt (9) for the titration of wool protein in the presence of 2,4,6-trinitroresorcinol, picric acid, or flavianic acid.

By means of the equation described above, the extrapolation of Curves A and B to infinite hydrogen ion concentration indicates that the maximal number of bound hydrogen ions per albumin molecule is 107 in each case. This number agrees with that found by Tanford (10). Thus, the charge on the albumin molecule in extremely acid solutions in the presence of that concentration of PF8 represented by a molar ratio (PF8 to albumin) of 196 does not exceed 28; 79 PF8 anions are bound under these conditions. The dotted line in Fig. 3 represents the difference between Curves A and B as a function of pH. The maximal difference between the two curves is near pH 4.25 at which an extra 64 hydrogen ions are bound by the albumin in the presence of PF8. The significance of the coincidence between the 64 extra hydrogen ions and the 63 strongly bound PF8 anions which are bound to the albumin is not known at this time; but the coincidence is so striking that it is brought to attention. Finally, it is apparent that Curves A and B coincide above pH 8. This is additional, although inconclusive, evidence that the PF8 completely dissociates from the albumin molecule in alkaline solutions.

#### SUMMARY

It has been shown that human serum albumin can be reversibly precipitated from aqueous solution under mildly acid conditions in the presence of low concentrations of perfluorooctanoic acid. In the formation of the

precipitate, the albumin molecule binds both hydrogen ions and perfluorooctanoate ions to form, under the conditions of the experiments described, a complex that has a net charge of almost zero.

Acknowledgment is made to the Cutter Laboratories for a sample of Fraction V (11), decanol human serum albumin, and to the Minnesota Mining and Manufacturing Company for a sample of perfluorooctanoic acid. Carboxyl-labeled ( $C^{14}$ ) perfluorooctanoic acid was obtained through the Atomic Energy Commission from the Minnesota Mining and Manufacturing Company.

*Addendum*—Klevens and Ellenbogen have recently published their research on the van der Waals association of bovine serum albumin in the presence of perfluoro acids (12).

#### BIBLIOGRAPHY

1. Kauck, E. A., and Diesslin, A. R., *Ind. and Eng. Chem.*, **43**, 2332 (1951).
2. Luck, J. M., Griffin, A. C., Boer, G., and Wilson, M., *J. Biol. Chem.*, **206**, 767 (1954).
3. McIlvaine, T. C., *J. Biol. Chem.*, **49**, 183 (1921).
4. Charlwood, P. A., *Biochem. J.*, **51**, 113 (1952).
5. Lowry, O. H., Rosebrough, N. J., Farr, A. L., and Randall, R. J., *J. Biol. Chem.*, **193**, 265 (1951).
6. Nye, W. N., and Teresi, J. D., *Anal. Chem.*, **23**, 643 (1951).
7. Klotz, I. M., *Arch. Biochem.*, **9**, 109 (1946).
8. Teresi, J. D., and Luck, J. M., *J. Biol. Chem.*, **194**, 823 (1952).
9. Steinhardt, J., *Ann. New York Acad. Sc.*, **41**, 287 (1941).
10. Tanford, C., *J. Am. Chem. Soc.*, **72**, 441 (1950).
11. Cohn, E. J., Gurd, F. R. N., Surgenor, D. M., Barnes, B. A., Brown, R. K., Derouaux, G., Gillespie, J. M., Kahnt, F. W., Lever, W. F., Liu, C. H., Mittelman, D., Mouton, R. F., Schmid, K., and Uroma, E., *J. Am. Chem. Soc.*, **72**, 465 (1950).
12. Klevens, H. B., and Ellenbogen, E., *Discussions Faraday Soc.*, **18**, 277 (1954).

**PERFLUOROOCCTANOIC ACID  
INTERACTIONS WITH HUMAN SERUM  
ALBUMIN**

Gordon L. Nordby and J. Murray Luck

*J. Biol. Chem.* 1956, 219:399-404.

---

Access the most updated version of this article at  
<http://www.jbc.org/content/219/1/399.citation>

Alerts:

- [When this article is cited](#)
- [When a correction for this article is posted](#)

[Click here](#) to choose from all of JBC's e-mail alerts

This article cites 0 references, 0 of which can be accessed free at  
<http://www.jbc.org/content/219/1/399.citation.full.html#ref-list-1>